



NARDELLI

A arte de fazer o seu dia melhor



ÍNDICE

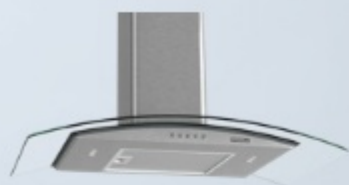

COIFAS E DEPURADORES

03



COOKTOPS

12



FORNOS DE EMBUTIR
(ELÉTRICOS E A GÁS)

20



FORNOS DE BANCADA
(ELÉTRICOS)

23



SUPER FOGO

29

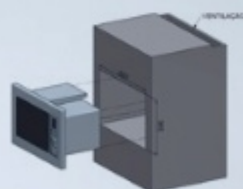

ESPECIFICAÇÕES TÉCNICAS

30



LEGENDAS ICONES

37

COIFAS



Coifa de Parede Vidro Curvo Clean

60cm - Cód. 46010160

70cm - Cód. 46010170

75cm - Cód. 46010175

80cm - Cód. 46010180

90cm - Cód. 46010190

KROMANOX

Derivação

127V - 14

220V - 15

CARACTERÍSTICAS



Fixar na parede



Efeito de aço escovado com alta resistência



127V ou 220V



Tamanhos disponíveis 60, 70, 75, 80 e 90cm



"No fingerprint" (sem marca de digitais)



60 e 70 cm: para cooktops/ fogões de 04 bocas



Modo exaustor



3 Velocidades



75, 80 e 90 cm: para cooktops/ fogões de 05 bocas



Modo depurador



Filtro carvão ativado



Cabe no seu espaço



Modo Depurador/ Exaustor: Sucção 550m³/h



Filtro alumínio



2 Placas de LED 3W



Soft Mechanic



Duto sanfonado Ø 127mm (não acompanha o produto)





PRETO

Derivação
127V - 02
220V - 03

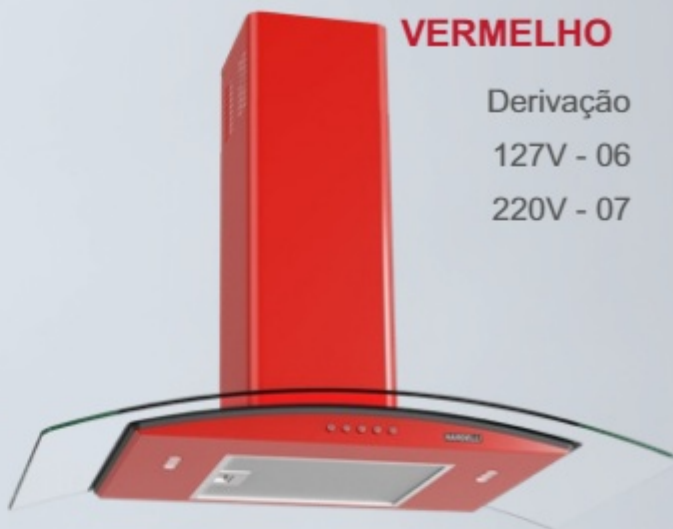

VERMELHO

Derivação
127V - 06
220V - 07



AMARELO

Derivação
127V - 08
220V - 09





Coifa de Parede Vidro Curvo Slim Inox

60cm - Cód. 50011000

70cm - Cód. 50011010

75cm - Cód. 50011015

80cm - Cód. 50011020

90cm - Cód. 50011030

Derivação

127V - 1

220V - 2

CARACTERÍSTICAS



Fixar na parede



Acabamento em
inox escovado



127V ou 220V



Tamanhos disponíveis
60, 70, 75, 80 e 90cm



3 Velocidades



60 e 70 cm: para
cooktops/ fogões
de 04 bocas



Modo exaustor



Filtro carvão
ativado



75, 80 e 90 cm: para
cooktops/ fogões
de 05 bocas



Modo depurador



Filtro alumínio



Cabe no seu espaço



Modo Depurador/
Exaustor: Sucção 550m³/h



Duto sanfonado
Ø 127mm
(não acompanha o produto)



2 Lâmpadas de LED



Painel Easy Touch





Coifa de Parede Vidro Reto Slim Inox

60cm - Cód. 50012300

70cm - Cód. 50012310

75cm - Cód. 50012315

80cm - Cód. 50012320

90cm - Cód. 50012330

Derivação

127V - 1

220V - 2

CARACTERÍSTICAS



Fixar na parede



Acabamento em
inox escovado



127V ou 220V



Tamanhos disponíveis
60, 70, 75, 80 e 90cm



3 Velocidades



60 e 70 cm: para
cooktops/ fogões
de 04 bocas



Modo exaustor



Filtro carvão
ativado



75, 80 e 90 cm: para
cooktops/ fogões
de 05 bocas



Modo depurador



Filtro alumínio



Cabe no seu espaço



Modo Depurador/
Exaustor: Sucção
550m³/h



Duto sanfonado
Ø 127mm
(não acompanha o produto)



2 Lâmpadas de LED



Painel Easy Touch





Coifa de Parede Retangular Slim Inox

60cm - Cód. 50010900

75cm - Cód. 50010915

90cm - Cód. 50010930

Derivação

127V - 1

220V - 2

CARACTERÍSTICAS



Fixar na parede



Acabamento em inox escovado



127V ou 220V



Tamanhos disponíveis 60, 75, e 90cm



3 Velocidades



60 e 75 cm: para cooktops/ fogões de 04 bocas



Modo exaustor



Filtro carvão ativado



75 e 90 cm: para cooktops/ fogões de 05 bocas



Modo depurador



Filtro alumínio

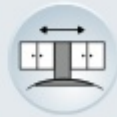

Cabe no seu espaço



Modo Depurador/ Exaustor: Sucção 550m³/h



Duto sanfonado Ø 127mm (não acompanha o produto)



2 Lâmpadas de LED



Painel Easy Touch

Segurança



Compulsório





Coifa Ilha Vidro Curvo Inox

75cm - Cód. 50011425

90cm - Cód. 50011410

Derivação

127V - 1

220V - 2

CARACTERÍSTICAS



Fixar no teto



Acabamento em
inox escovado



127V ou 220V



Tamanhos disponíveis
75 e 90cm



3 Velocidades



75 cm: para
cooktops/ fogões
de 04 bocas



Modo exaustor:
sucção até 900m³/h



Filtro carvão
ativado



75 e 90 cm: para
cooktops/ fogões
de 05 bocas



Modo depurador:
sucção até 700m³/h



Filtro alumínio

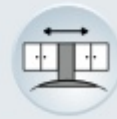

Cabe no seu espaço



Painel easy touch



Duto sanfonado
Ø 150mm
(não acompanha o produto)



4 Placas de LED 3W

Segurança



Compulsório



Coifa Ilha Vidro Reto Inox



Inox

60cm - Cód. 50011405
75cm - Cód. 50011415
90cm - Cód. 50011400

Derivação
127V - 1
220V - 2

Preto

60cm - Cód. 50014145
75cm - Cód. 50014135
90cm - Cód. 50014155

CARACTERÍSTICAS



Fixar no teto



Acabamento em inox escovado ou pintura microtextura



127V ou 220V



Tamanhos disponíveis 60, 75, e 90cm



3 Velocidades



60 e 75 cm: para cooktops/ fogões de 04 bocas



Modo exaustor até 900m³/h



Filtro carvão ativado



75 e 90 cm: para cooktops/ fogões de 05 bocas



Modo depurador até 700m³/h



Filtro alumínio



Cabe no seu espaço



Painel Easy Touch



Duto sanfonado Ø 150mm (não acompanha o produto)



4 Placas de LED 3W

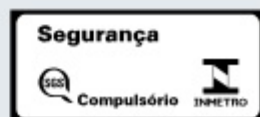

Coifa Ilha Retangular Inox

60cm - Cód. 50011800

75cm - Cód. 50011815

90cm - Cód. 50011830

120cm - Cód. 50011865

Derivação

127V - 1

220V - 2



CARACTERÍSTICAS



Fixar no teto



Acabamento em
inox escovado



127V ou 220V



Tamanhos disponíveis
60, 75, 90



3 Velocidades



60 e 75 cm: para
cooktops/ fogões
de 04 bocas



Modo exaustor:
sucção até 900m³/h



Filtro Carvão
Ativado



75 e 90:
para cooktops
de 05 bocas



Modo depurador:
sucção até 700m³/h



Filtro alumínio



Cabe no seu espaço



Painel easy touch



Duto sanfonado
Ø 150mm
(não acompanha o produto)



4 Lâmpadas de LED

Segurança



Compulsório



INMETRO

Depurador Compact New

Inox

60cm - Cód. 18015900

75cm - Cód. 18015915

90cm - Cód. 18015930

Derivação

127V - 1

220V - 2

Black

60cm - Cód. 45010660 **Derivação**

75cm - Cód. 45010675 127V - 02

90cm - Cód. 45010690 220V - 03

CARACTERÍSTICAS



Fixar em móvel



Acabamento em inox escovado ou pintura microtextura



127V ou 220V



Tamanhos disponíveis 60, 75, e 90cm



3 Velocidades



60 e 75 cm: para cooktops/ fogões de 04 bocas



Modo exaustor



Filtro carvão ativado



75 e 90 cm: para cooktops/ fogões de 05 bocas



Modo depurador



Filtro alumínio



2 Placas de LED 3W



Modo Depurador/ Exaustor: Sucção 550m³/h



Duto sanfonado Ø 127mm (não acompanha o produto)



Painel easy touch

Segurança



Compulsório



COOKTOPS SAFE

Cooktop SAFE 2B

LANÇAMENTO



2 Bocas Inox

Cód. 27011201

Derivação

127V / 220v - 00

Manípulos

Trempe de Ferro fundido

Novo design

1 ANO
GARANTIA

CARACTERÍSTICAS



Vidro temperado preto



Bivolt



1 semirrápido:
1600 W



Manípulos removíveis



28 a 37mBar



1 rápido:
2800 W



Acendedor Automático



Gás GLP



Selo Conpet A



Disponível com Flange inox



NOVO Sistema anti rotação



Cooktop SAFE 4B

LANÇAMENTO

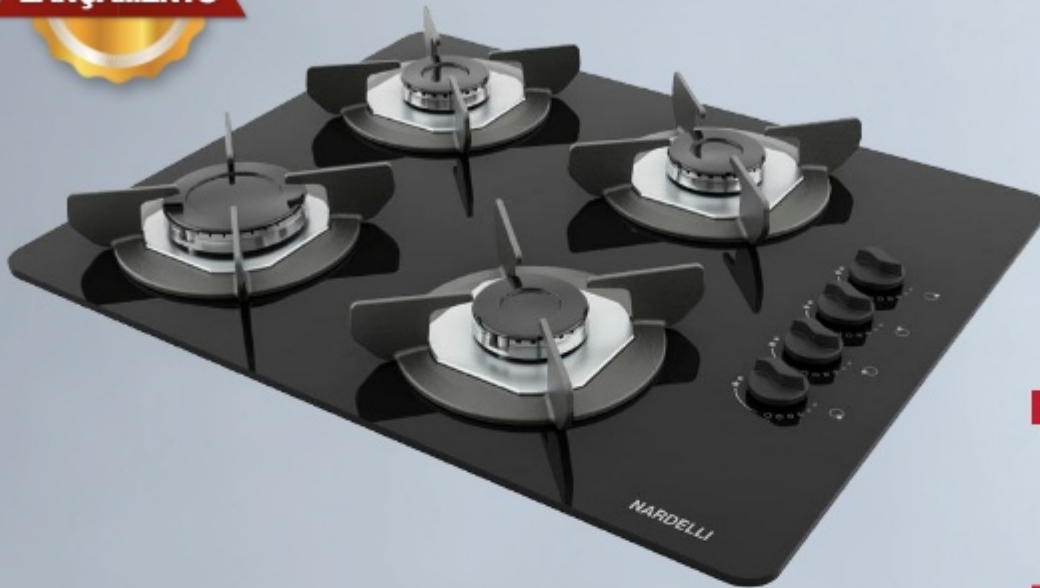

4 Bocas Inox

Cód.27011301

Derivação

127V / 220v - 00

Manípulos

Trempe de Ferro fundido

Novo design

1 ANO
GARANTIA

CARACTERÍSTICAS



Vidro temperado preto



Bivolt



3 semirrápidos:
1600 W



Manípulos removíveis



28 a 37mBar



1 rápido:
2800 W



Acendedor Automático



Gás GLP



Selo Conpet A



Disponível com Flange inox



NOVO Sistema anti rotação



Cooktop SAFE 5B

LANÇAMENTO

5 Bocas Inox

Cód.27011401-00

Derivação

127V / 220v - 00



Manípulos

Trempe de Ferro fundido

Novo design

1 ANO
GARANTIA

CARACTERÍSTICAS



Vidro temperado preto



Bivolt



3 semirrâpidos:
1600 W



Manípulos removíveis



28 a 37mBar

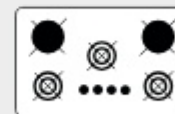

2 rápidos:
2800 W



Acendedor Automático



Gás GLP



Selo Conpet A



Disponível com Flange inox



NOVO Sistema anti rotação



Trempe (grade) em ferro fundido.

Cooktop SAFE 5B TC

LANÇAMENTO

5 Bocas TC Inox

Cód.27011601

Derivação

127V / 220v - 00



Manípulos

Trempe de Ferro fundido

Novo design

1 ANO
GARANTIA

CARACTERÍSTICAS



Vidro temperado preto



Bivolt



2 semirrápidos:
1600 W



Manípulos removíveis



28 a 37mBar



2 rápido:
2800 W



Acendedor Automático



Tripla chama (TC)



1 ultrarrápido tripla chama:
3400 W



Disponível com Flange inox



Gás GLP



Selo Conpet A



Trempe (grade) em ferro fundido.



NOVO Sistema anti rotação



COOKTOPS NDL

Cooktop NDL 2B



2 Bocas Inox

Cód. 27010001

Derivação

127V / 220v - 00

2 Bocas Esmaltado

Cód. 27010001/02



Manípulos



Flange esmaltada



Novo design

CARACTERÍSTICAS



Vidro temperado preto



Bivolt



1 semirrápido:
1600 W



Manípulos removíveis



28 a 37mBar



1 rápido:
2800 W



Acendedor Automático



Gás GLP



Selo Conpet A



Disponível com fange esmaltada na cor preta



NOVO Sistema anti rotação

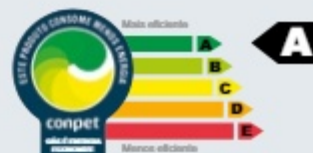



Cooktop NDL 4B

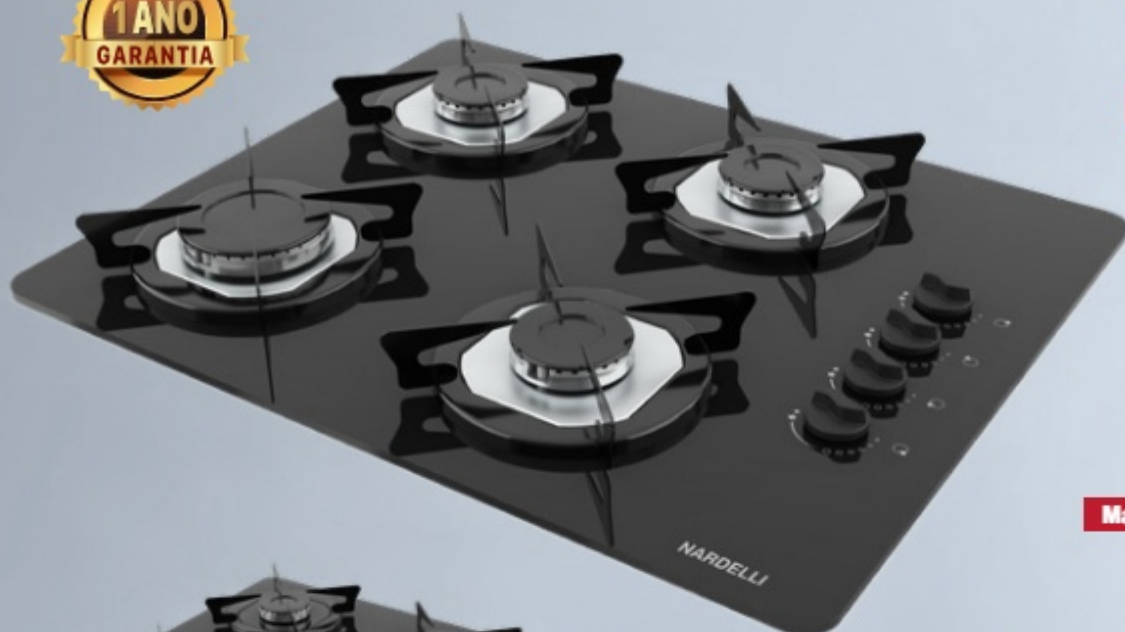

4 Bocas Inox

Cód. 27010101

Derivação

127V / 220v - 00



Manipulos



Flange esmaltada



Novo design

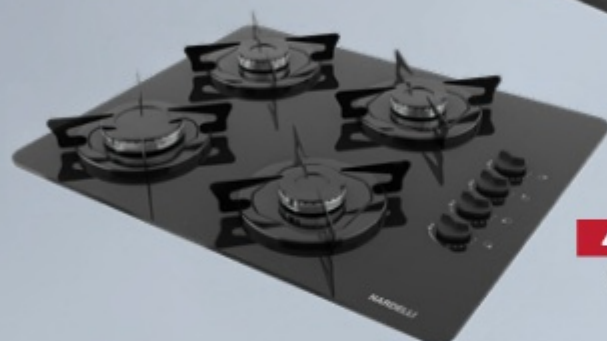

4 Bocas Esmaltado

Cód. 27010101/02

CARACTERÍSTICAS



Vidro temperado preto



Bivolt



3 semirrâpidos:
1600 W



Manipulos removíveis



28 a 37mBar



1 rápido:
2800 W



Acendedor Automático



Gás GLP



Selo Conpet A



Disponível com fange esmaltada na cor preta



NOVO Sistema anti rotação



Cooktop NDL 5B



5 Bocas Inox

Cód.27010201

Derivação

127V / 220v - 00



Manipulos

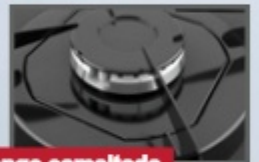

Flange esmaltada



Novo design

5 Bocas Esmaltado

Cód.27010201/02

CARACTERÍSTICAS



Vidro temperado preto



Bivolt



3 semirrâpidos:
1600 W



Manipulos removíveis



28 a 37mBar



2 rápidos:
2800 W



Acendedor Automático



Gás GLP



Selo Conpet A



Disponível com fange esmaltada na cor preta



NOVO Sistema anti rotação



Cooktop NDL 5B TC



5 Bocas TC Inox

Cód.27010501

Derivação

127V / 220v - 00

5 Bocas TC Esmaltado

Cód.27010501/02

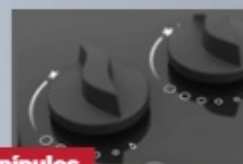

Manípulos



Flange esmaltada



Novo design

CARACTERÍSTICAS



Vidro temperado preto



Bivolt



2 semirrâpidos:
1600 W



Manípulos removíveis



28 a 37mBar

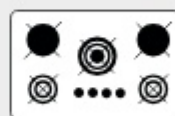

2 rápido:
2800 W



Acendedor Automático



Tripla chama (TC)



1 ultrarrápido tripla chama:
3400 W



Disponível com fange esmaltada na cor preta



Gás GLP



Selo Conpet A



NOVO Sistema anti rotação

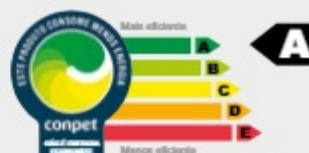

FORNOS

Forno E60 Inox (60 Litros de Embutir Elétrico)

Cód. 10016351

E60 Black

Cód. 10016354

Obs.: Botão normal,
não é retrátil



Botão retrátil



Vista interna

Derivação

127V - 1

220V - 2

CARACTERÍSTICAS



Controle automático de temperatura



Grill / Dourador



Resist. Superior: 750 W



De embutir



Luz interna e luz piloto



Resist. Inferior: 1000 W



Fácil Limpeza:
Interior em Esmalte
Easy Clean



Timer de até
Até 120min



Potência total:
1750 W



Isolamento térmico



Aquece até 300°C



Acompanha
Grelha e Bandeja



Para formas de até 40cm



Botões retráteis
exclusivo na versão inox



Forno G57

(57 Litros de Embutir à Gás)

Cód. 10017733

Derivação

127V - 1

220V - 2



Sistema de resfriamento
VIDRO NÃO AQUECE!

Porta vidro duplo com possibilidade de remoção para facilitar a limpeza.



Vista interna

CARACTERÍSTICAS



Controle automático de temperatura



Grill / Dourador



Potencia do Grill: 700 W



De embutir



Luz interna e luz piloto



Para formas de até 40cm



Fácil Limpeza: Interior em Esmalte Easy Clean



Timer de até Até 120min



Aquece até 300°C



Isolamento térmico



Gás GLP



Forno ESI / ESP

(45 Litros de Embutir Elétrico)



ESI
Cód. 10015078

Derivação
127V - 1
220V - 2



ESP
Cód. 10015178



Vista interna



Porta vidro duplo com possibilidade de remoção para facilitar a limpeza.

CARACTERÍSTICAS



Controle automático de temperatura



Grill / Dourador



Resist. Superior: 700 W



De embutir



Luz interna e luz piloto



Resist. Inferior: 1000 W



Autolimpante



Timer de até Até 120min



Potência total: 1700 W



Isolamento térmico



Aquece até 300°C



Botões retráteis



Para forma Redonda 35cm Retangular 45x35 cm



Acompanha Grelha e Bandeja



Forno Smart 60's

(60 Litros de Bancada Elétrico)

Cód. 10014031

COM
ESPETO GIRATÓRIO



Vista interna



Derivação

127V - 1

220V - 2

CARACTERÍSTICAS



luz piloto



Grill / Dourador



Timer de até
até 120min



Controle automático
de temperatura



Aquece até 300°C



Potência total:
1750 W



Resist. Superior:
700 W



Resist. Inferior:
1050 W



Fácil Limpeza:
Interior em Esmalte
Easy Clean



Pés antiderrapantes



Com espeto
Giratório





TOP60 Vermelho

Cód. 10014752



TOP60 Azul

Cód. 10014753



Vista interna

Derivação
127V - 1
220V - 2

Forno TOP60 (60 litros de Bancada Elétrico)



TOP60 Preto

Cód. 10014754



CARACTERÍSTICAS



**Luz Interna +
Luz Piloto**



Grill / Dourador



**Timer de até
até 120min**



**Resist. Superior:
700W**



**Resist. Inferior:
1050 W**



**Potência total:
1750 W**



Pés antiderrapantes



**Aquece até
300°C**



**Controle automático
de temperatura**



**Acompanha Grelha
e Bandeja**



**Fácil Limpeza:
Interior em Esmalte
Easy Clean**



Forno TOP 48

(48 litros de Bancada Elétrico)

Cód. 10015463

Derivação

127V - 1

220V - 2



Vista interna

CARACTERÍSTICAS



Luz interna e luz piloto



Grill / Dourador



Timer de até até 120min



Controle automático de temperatura



Aquece até 300°C



Potência total: 1750 W



Resist. Superior: 750 W



Resist. Inferior: 1000 W



Fácil Limpeza: Interior em Esmalte Easy Clean



Pés antiderrapantes



Isolamento térmico



Forno TOP 40

(40 litros de Bancada Elétrico)

Cód. 10014979

Derivação

127V - 1

220V - 2



Vista interna



CARACTERÍSTICAS



Luz piloto



Grill / Dourador



Timer de até
até 120min



Controle automático
de temperatura



Aquece até 300°C



Potência total:
1700 W



Resist. Superior:
700 W



Resist. Inferior:
1000 W



Fácil Limpeza:
Interior em Esmalte
Easy Clean



Pés antiderrapantes



Para formas
de até 35cm



Forno Calábria

(45 litros de Bancada Elétrico)

Cód. 10011340

Derivação

127V - 1

220V - 2



CARACTERÍSTICAS



Luz interna e luz piloto



Grill / Dourador



Timer de até 120min



Controle automático de temperatura



Aquece até 300°C



Potência total: 1700 W



Resist. Superior: 700 W



Resist. Inferior: 1000 W



Isolamento térmico



Pés antiderrapantes



Para formas de até 40cm



Fácil Limpeza: Chapa especial com acabamento Autolimpante



Forno Calábria Black

(45 litros de Bancada Elétrico)

Cód. 10010173

Derivação

127V - 1

220V - 2



CARACTERÍSTICAS



Luz interna e luz piloto



Grill / Dourador



Timer de até até 120min



Controle automático de temperatura



Aquece até 300°C



Potência total: 1700 W



Resist. Superior: 700 W



Resist. Inferior: 1000 W



Isolamento térmico



Pés antiderrapantes



Para formas de até 40cm



Fácil Limpeza: Interior em Esmalte Easy Clean



ACENDEDOR

Super Fogo

Cód. 12013300

Derivação

127V - 1

220V - 2



CARACTERÍSTICAS



127V ou 220V



Atinge até 315°C



praticidade e
segurança



Dispensa o uso
de álcool e outros
produtos tóxicos



Rápido acendimento
de carvão



Sem fumaça, e
sem labaredas



para lareiras e
churrasqueiras

ESPECIFICAÇÕES

Coifa de Parede Vidro Curvo - Pag. 3 e 5

Tensão: 127V ou 220V;
Frequência: 60 Hz;
Ruído: 65 Db;
Potência do motor: 140 W;
Potência total: 142 W;
Velocidades: 3;
Potência lâmpada: 2 LED 1W;
Consumo: 0,142 kWh;

Dimensões e peso da coifa
A 100cm x L 90cm x P 45cm – 10,39kg
A 100cm x L 80cm x P 45cm – 9,80kg
A 100cm x L 75cm x P 45cm – 9,65kg
A 100cm x L 70cm x P 45cm – 9,35kg
A 100cm x L 60cm x P 45cm – 8,99kg
Dimensões do duto
A 50cm x L 21cm x P 20,5cm
Altura total Duto = 93cm

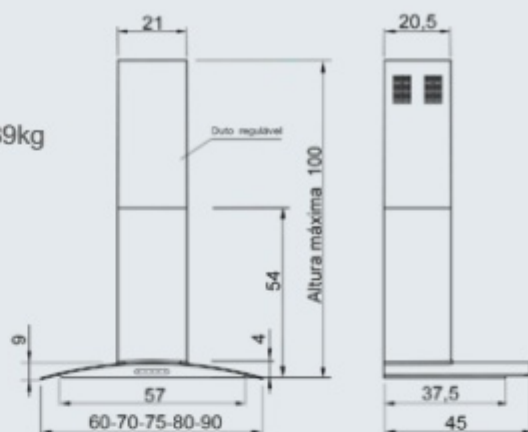

Coifa de Parede Vidro Reto - Pag. 6

Tensão: 127V ou 220V;
Frequência: 60 Hz;
Ruído: 65 Db;
Potência do motor: 140 W;
Potência total: 142 W;
Velocidades: 3;
Potência lâmpada: 2 LED 1W;
Consumo: 0,142 kWh;

Dimensões e peso da coifa:
A 100cm x L 90cm x P 45cm – 10,08kg
A 100cm x L 80cm x P 45cm – 9,80kg
A 100cm x L 75cm x P 45cm – 9,60kg
A 100cm x L 70cm x P 45cm – 9,30kg
A 100cm x L 60cm x P 45cm – 8,90kg;
Dimensões do duto:
A 50cm x L 21cm x P 20,5cm;
Altura total Duto: 93cm



Coifa de Parede Retangular - Pag. 7

Tensão: 127V ou 220V;
Frequência: 60 Hz;
Ruído: 65 Db;
Potência do motor: 140 W;
Potência total: 142 W;
Velocidades: 3;
Potência lâmpada: 2 LED 1W;
Consumo: 0,142 kWh;

Dimensões e peso da coifa:
A 100cm x L 90cm x P 47,5cm – 8,09kg
A 100cm x L 75cm x P 47,5cm – 7,25kg
A 100cm x L 60cm x P 47,5cm – 6,41kg
Dimensões do duto:
A 50cm x L 21cm x P 20,5cm;
Altura total Duto: 93cm.

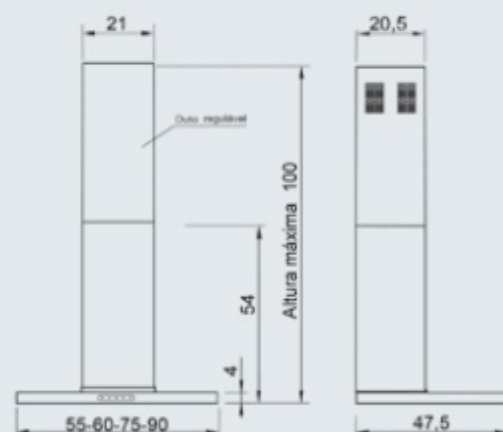

Coifa Ilha Vidro Curvo Inox - Pag. 8

Tensão: 127 V ou 220 V;
Frequência: 60 Hz;
Ruído: 65 dB;
Potência do motor: 240 W;
Potência total: 244 W;
Velocidades: 3;
Potência lâmpada:
4 Placas de LED 3W
Consumo: 0,244 kWh;

Dimensões e peso da coifa:
A 95cm x L 90cm x P 60cm – 25,0kg
A 95cm x L 75cm x P 60cm – 23,6kg
Dimensões do duto:
A 49,5cm x L 32cm x P 28cm;
Altura total Duto: 85cm.

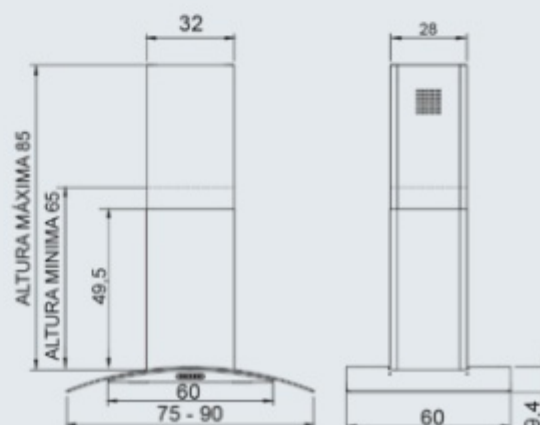

Coifa de Ilha Vidro Reto - Pag. 9

Tensão: 127V ou 220V;
Frequência: 60 Hz;
Ruído: 65 Db;
Potência do motor: 240 W;
Potência total: 244 W;
Velocidades: 3;
Potência lâmpada:
4 Placas de LED 3W;
Consumo: 0,244 kWh;

Dimensões e peso da coifa:
A 90cm x L 90cm x P 60cm – 25,0kg
A 90cm x L 75cm x P 60cm – 23,6kg
A 90cm x L 60cm x P 60cm – 22,2kg
Dimensões do duto:
A 49,5cm x L 32cm x P 28cm;
Altura total Duto: 85cm

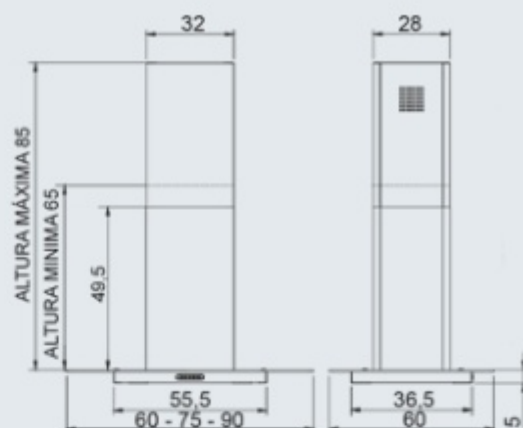

Coifa Ilha Retangular Inox - Pag. 10

Tensão: 127 V ou 220 V;
Frequência: 60 Hz;
Ruído: 65 dB;
Potência do motor: 240 W;
Potência total: 244 W;
Velocidades: 3;
Potência lâmpada: 4 LED 1W;
Consumo: 0,244 kWh;

Dimensões e peso da coifa:
A 120cm x L 120cm x P 60cm – 28,00kg
A 90cm x L 90cm x P 60cm – 21,80kg
A 90cm x L 75cm x P 60cm – 21,14kg
A 90cm x L 60cm x P 60cm – 19,86kg;
Dimensões do duto:
A 49,5cm x L 32cm x P 28cm:
Altura total Duto: 85cm.

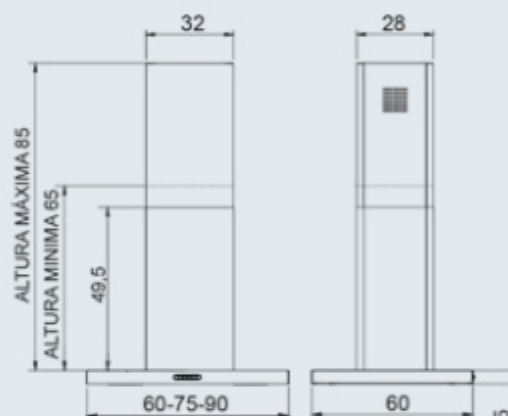

Depurador Compact New - Pag. 11

Tensão: 127V ou 220V;
Frequência: 60 Hz;
Ruído: 65 Db;
Potência do motor: 140 W;
Potência total: 142 W;
Velocidades: 3;
Potência lâmpada:
2 Placas de LED 3W;
Consumo: 0,142 kWh;

Dimensões e peso do depurador (base):
A 4cm x L 90cm x P 33,5cm – 7,5kg
A 4cm x L 75cm x P 33,5cm – 7,0kg
A 4cm x L 60cm x P 33,5cm – 6,5kg
Dimensões do motor – interno/embutido:
A 25cm x L 23cm x P 22cm;
Altura total necessária: 29cm

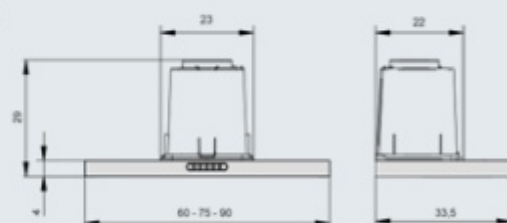

Cooktop SAFE 2B-Pag. 12

Tensão: Bivolt;
Frequência: 50/60 Hz;
Consumo de Gás: 0,3454 kg/h;
Potência: 0,96 W (127V)
2,75 W (220V);
Queimadores: 1 Rápido 2,8 kW
1 Semi-rápido 1,6kW;
Pressão do Gás: 28 a 37 mBar;

Tipo Gás: GLP;
Dimensões do Produto:
A 11,5cm x L 51cm x P 31cm
Dimensões do Nicho:
A 20cm x L 46,5cm x P 27,5cm
Peso: 5,0kg

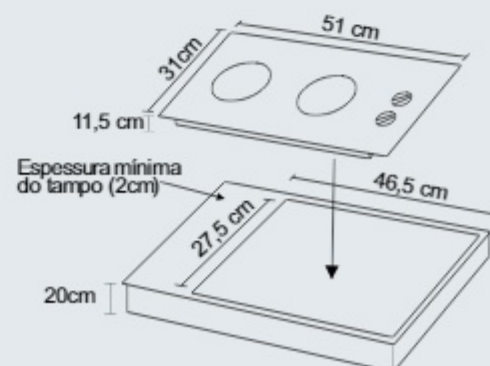

Cooktop SAFE 4B-Pag. 13

Tensão: Bivolt;
Frequência: 50/60 Hz;
Consumo de Gás: 0,6001 kg/h;
Potência: 0,96 W (127V)
2,75 W (220V);
Queimadores: 1 Rápido 2,8 kW
3 Semi-rápidos 1,6kW

Pressão do Gás: 28 a 37 mBar;
Tipo Gás: GLP
Dimensões do Produto:
A 11,5cm x L 55cm x P 46cm
Dimensões do Nicho:
A 20cm x L 50cm x P 37cm
Peso: 6,7kg

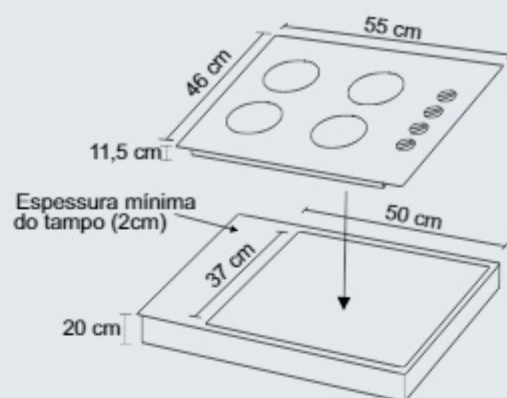

Cooktop SAFE 5B-Pag. 14

Tensão: Bivolt;
Frequência: 50/60 Hz;
Consumo de Gás: 0,8183 kg/h;
Potência: 0,96 W (127V)
2,75 W (220V);
Queimadores: 2 Rápidos 2,8 kW
3 Semi-rápidos 1,6 kW

Pressão do Gás: 28 a 37 mBar;
Tipo Gás: GLP
Dimensões do Produto:
A 11,5cm x L 68,5cm x P 46cm
Dimensões do Nicho:
A 20cm x L 60,5cm x P 34cm
Peso: 8,3kg

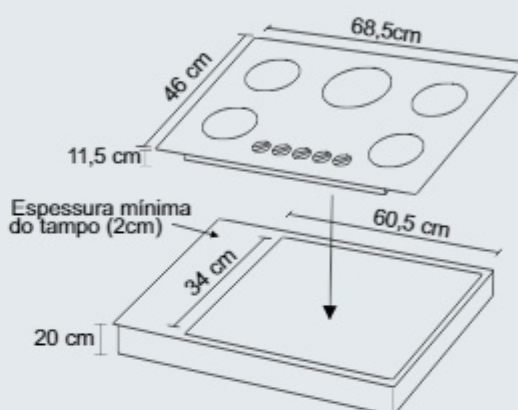

Cooktop SAFE 5B TC-Pag. 15

Tensão: Bivolt;
Frequência: 50/60 Hz;
Consumo de Gás: 0,966 kg/h;
Potência: 0,96 W (127V)
2,75 W (220V);
Queimadores: 1 Ultra Rápido 3,4 kW
2 Rápidos 2,8 kW
2 Semi-rápidos 1,6 kW

Pressão do Gás: 28 a 37 mBar;
Tipo Gás: GLP
Dimensões do Produto:
A 11,5cm x L 68,5cm x P 46cm;
Dimensões do Nicho:
A 20cm x L 60,5cm x P 34cm;
Peso: 8,8kg.

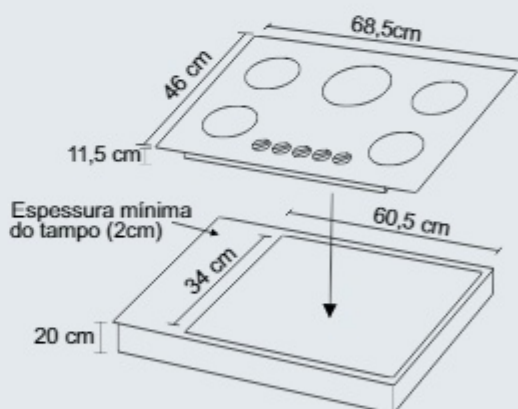

Cooktop NDL 2B - Pag. 16

Tensão: Bivolt;
Frequência: 50/60 Hz;
Consumo de Gás: 0,3454 kg/h;
Potência: 0,96 W (127V)
2,75 W (220V);
Queimadores: 1 Rápido 2,8 kW
1 Semi-rápido 1,6kW;
Pressão do Gás: 28 a 37 mBar;

Tipo Gás: GLP;
Dimensões do Produto:
A 11,5cm x L 51cm x P 31cm
Dimensões do Nicho:
A 20cm x L 46,5cm x P 27,5cm
Peso: 5,0kg

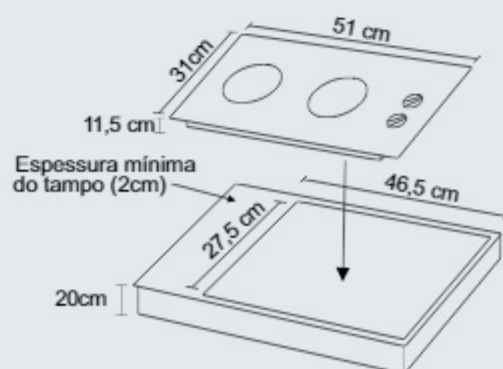

Cooktop NDL 4B - Pag. 17

Tensão: Bivolt;
Frequência: 50/60 Hz;
Consumo de Gás: 0,6001 kg/h;
Potência: 0,96 W (127V)
2,75 W (220V);
Queimadores: 1 Rápido 2,8 kW
3 Semi-rápidos 1,6kW

Pressão do Gás: 28 a 37 mBar;
Tipo Gás: GLP
Dimensões do Produto:
A 11,5cm x L 55cm x P 46cm
Dimensões do Nicho:
A 20cm x L 50cm x P 37cm
Peso: 6,7kg

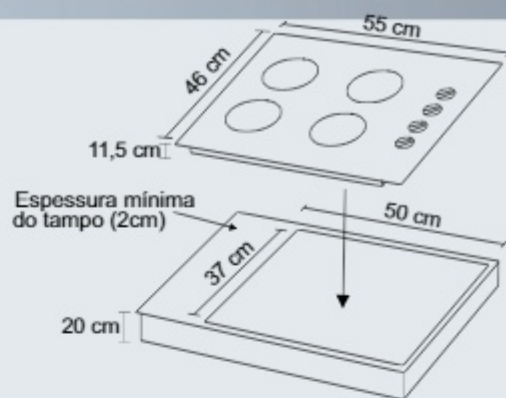

Cooktop NDL 5B - Pag. 18

Tensão: Bivolt;
Frequência: 50/60 Hz;
Consumo de Gás: 0,8183 kg/h;
Potência: 0,96 W (127V)
2,75 W (220V);
Queimadores: 2 Rápidos 2,8 kW
3 Semi-rápidos 1,6 kW

Pressão do Gás: 28 a 37 mBar;
Tipo Gás: GLP
Dimensões do Produto:
A 11,5cm x L 68,5cm x P 46cm
Dimensões do Nicho:
A 20cm x L 60,5cm x P 34cm
Peso: 8,3kg

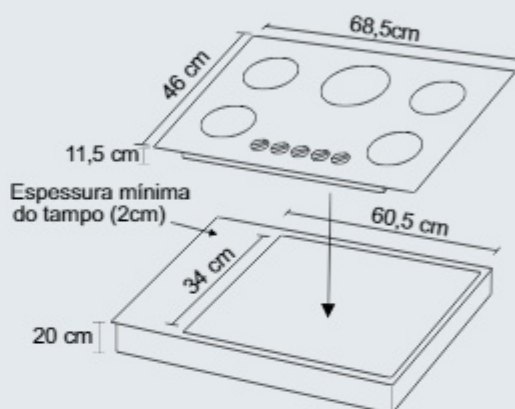

Cooktop NDL 5B TC - Pag. 19

Tensão: Bivolt;
Frequência: 50/60 Hz;
Consumo de Gás: 0,966 kg/h;
Potência: 0,96 W (127V)
2,75 W (220V);
Queimadores: 1 Ultra Rápido 3,4 kW
2 Rápidos 2,8 kW
2 Semi-rápidos 1,6 kW

Pressão do Gás: 28 a 37 mBar;
Tipo Gás: GLP
Dimensões do Produto:
A 11,5cm x L 68,5cm x P 46cm;
Dimensões do Nicho:
A 20cm x L 60,5cm x P 34cm;
Peso: 8,8kg.

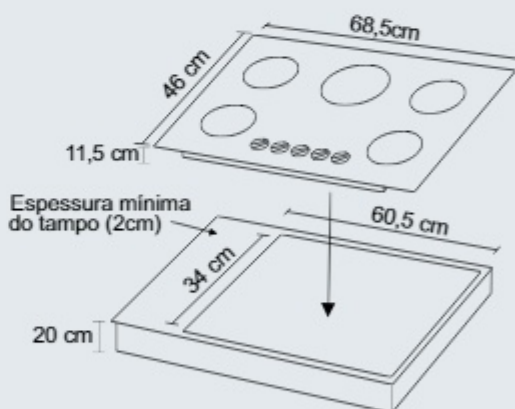

Forno E60 - Pag. 20

Tensão: 127 V / 220 V;
Corrente: 15 A (127v)
8 A (220V);
Frequência: 60 Hz;
Potência resist. Sup.: 700 W;
Potência resist. Inf.: 1000 W;
Potência total: 1700 W;

Consumo: 1,17 kWh;
Dimensões externas:
L600mm x A582mm x P420mm;
Dimensões do nicho:
L588mm x A555mm x P500mm;
Peso: 17kg.

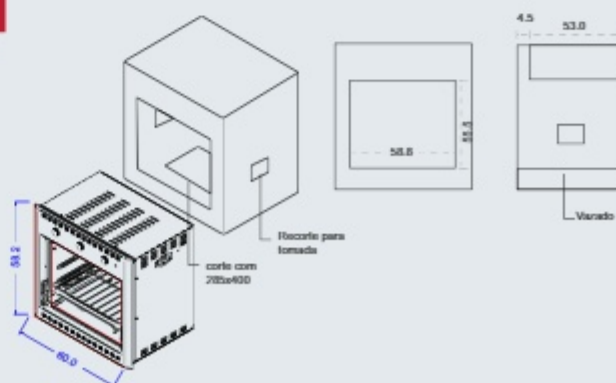

Forno G57 - Pag. 21

Tensão: 127 V / 220 V;
Corrente 1,12 A (127V);
0,65 A (220V);
Frequência 60Hz;
Potência Elétrica Grill: 700W
Consumo: 1,17 kWh;

Dimensões internas:
L: 575 mm X A: 414 mm X P: 451 mm;
Dimensões Internas:
L: 355 mm X P: 450 mm X A: 375 mm
Espaço interno: 60 L;
Peso: 25,9kg.

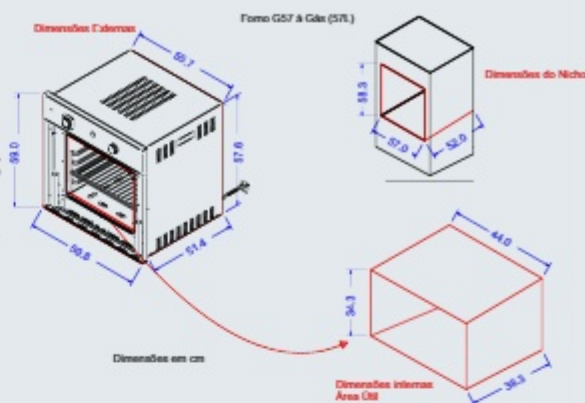

Forno 45L (ESI/ ESP) - Pag. 22

Tensão/Corrente 127 V / 220 V;
Frequência 60Hz;
Potência Elétrica Superior: 700W;
Potência Elétrica Inferior: 1700W;
Potência Elétrica Total: 1.700W;
Consumo: 1,2KWh;

Dimensões internas:
L 26,3cm x P 36,9cm x A 46,4,3cm;
Dimensões externas:
L 39cm x P 59,8cm x A 57,2cm;
Peso: 15kg

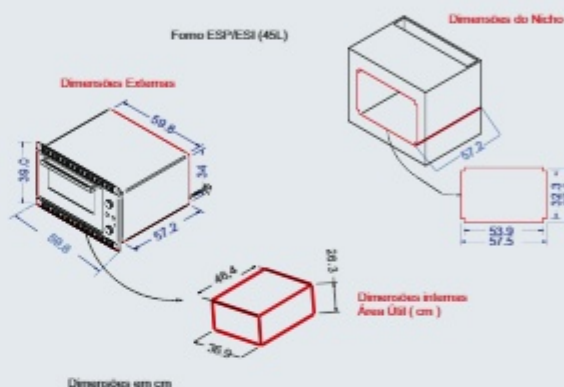

Forno Smart60's- Pag. 23

Tensão: 127 V / 220 V;
Corrente: 13,40 A (127 V);
7,70 A (220 V);
Frequência: 50/60 Hz;
Potência resist. Sup.: 700 W;
Potência resist. Inf.: 1050 W;
Potência total: 1750 W;

Consumo: 1,17 kWh;
Dimensões Externas:
L: 575 mm X A: 414 mm X P: 451 mm;
Dimensões Internas:
L: 355 mm X P: 450 mm X A: 375 mm
Espaço interno: 60 L;
Peso: 6,7kg.

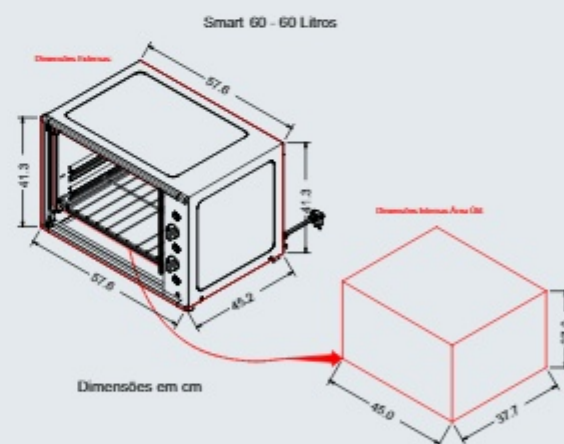

Forno TOP60 - Pag. 24

Tensão: 127 V / 220 V;
Corrente: 15 A (127 V);
8 A (220 V);
Frequência: 60 Hz;
Potência total: 1750 W;
Consumo: 1,2 kWh;

Dimensões Externas:
L: 575,3 mm X A: 412,5 mm X P: 451,3 mm;
Dimensões Internas:
L: 450 mm X P: 353,6 mm X A: 374,5 mm
Espaço interno: 60 L;
Peso: 6,7kg.

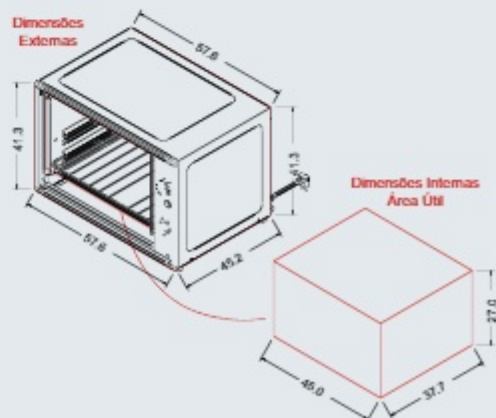

Forno TOP48 Pag. 25

Tensão: 127v ou 220v;
Corrente: 15 A (127v)
8 A (220v);
Frequência: 60Hz;
Potencia resistência Sup.: 750W;
Potencia resistência Inf.: 1000W;
Potencia total: 1750W;

Consumo: 1,2kWh
Dimensões externas do produto:
L 57,5 x A 33,7 x P 45,1 cm;
Dimensões internas:
L 45.1 x A 29.1 x P 37.0cm;
Espaço interno: 48 Litros;
Peso: 10,2kg

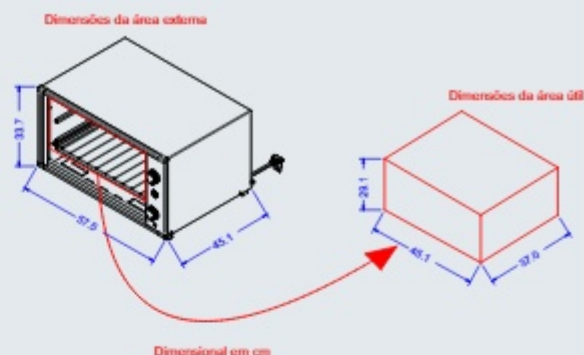

Forno TOP40 - Pag. 26

Tensão 127v ou 220v;
Corrente: 15 A (127v)
8 A (220v);
Frequência: 60Hz;
Potencia resistência Sup.: 700W;
Potencia resistência Inf.: 1000W;
Potencia total: 1700w;

Consumo: 1,2kWh
Dimensões externas do produto:
L 50,0 x A 34,4 x P 47,5 cm;
Dimensões internas:
L 37,0 x A 28,0 x P 39,5 cm;
Espaço interno: 40 Litros;
Peso: 10,2kg

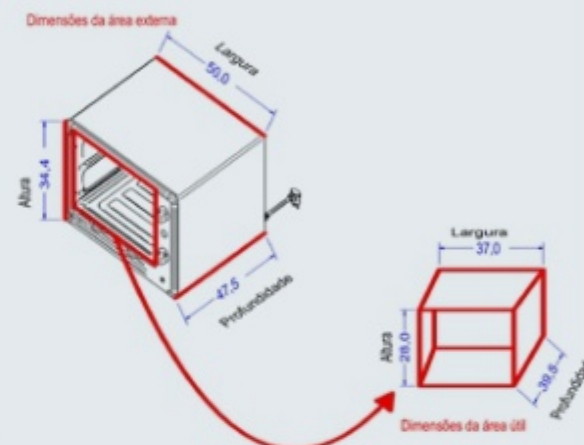

Forno Calábria - Pag. 27 e 28

Tensão: 127 V / 220 V;
Corrente: 13,40 A (127 V)
7,70 A (220 V);
Frequência: 50/60 Hz;
Potência resist. Sup.: 700 W;
Potência resist. Inf.: 1000 W;

Potência total: 1700 W;
Consumo: 1,17 kWh;
Dimensões externas:
L: 500 mm x A: 340 mm x P: 540 mm;
Espaço interno: 45 L.

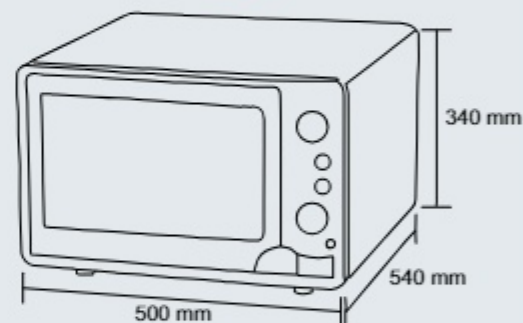

Super Fogo - Pag. 29

Tensão: 127 V / 220 V;
Corrente: 3,54 A (127 V)
2,05 A (220 V);
Potência total: 450 W
Consumo: 0,45 kWh

Dimensões externas do produto:
L: 450 mm x C: 70 mm

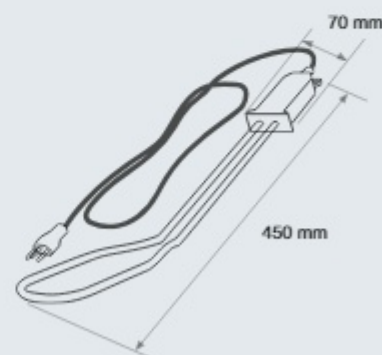

Legenda Coifas e Depurador



PAREDE: Indica que o modo de instalação e uso da coifa é de Parede.



VELOCIDADES: Indica quantas opções de velocidade o produto possui.



SUCÇÃO: Indica a capacidade de sucção da coifa.



ILHA: Indica que o modo de instalação e uso da coifa é de Ilha.



SLIM: Cabe no seu espaço, deixando moderno e elegante!



75-80-90 cm: Coifas dessa medida podem ser usadas para fogões de até 05 bocas



COMANDO: Indica o modelo do painel de comando da Coifa.



ACABAMENTO: Indica o principal material utilizado no acabamento do produto.



FILTRO DE ALUMÍNIO: Responsável por filtrar a gordura.



ILUMINAÇÃO: Indica se o produto possui luz, e sua quantidade.

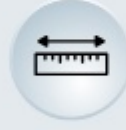

LARGURA: Informa as larguras disponíveis para o modelo de Coifa



TENSÃO: Indica em qual voltagem o produto está disponível: 127V, 220V ou Bivolt



DEPURADOR: Indica a opção de instalação do produto como Depurador.



TUBO SANFONADO: Informa o diâmetro de saída para o Tubo sanfonado, visto esta peça não acompanhar a coifa.



FILTRO DE CARVÃO: Responsável por filtrar o Odor.



EXAUSTOR: Indica a opção de instalação do produto como Exaustor.



60-70-75 cm: Coifas dessa medida podem ser usadas para fogões de até 04 bocas.



EMBUTIR: Indica que o produto deve ser fixo em móvel superior

Legenda Cooktops



ACABAMENTO: Indica o principal material utilizado no acabamento do produto.



VOLTAGEM: Indica a voltagem para acionamento do acendimento automático.



SISTEMA PIN: Sistema patenteado de fixação das grades que evita girar, trepidar ou deslocar.



MANÍPULOS: Indica que os botões são removíveis para limpeza.



PRESSÃO DO GÁS: Indica o máximo de pressão de gás que terá durante o cozimento.



FLANGE ESMALTADA: indica que os modelos esmaltados possuem a fange esmaltada na cor preta.



ACENDIMENTO: Acendimento automático: Não precisa de acendedores (esqueiros, fósforos etc...).



GÁS GLP: Produto apenas para alimentação à Gás GLP (Botijão).

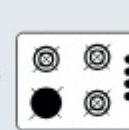

QUEIMADORES: Indica a potência de cada queimador.



CLASSIFICAÇÃO ENERGÉTICA: Indica a classificação de consumo energético (gás ou energia).



TRIPLA CHAMA (TC): Indica que um dos queimadores possui maior potência.



SISTEMA ANTI ROTAÇÃO: Mantem a grade fixa e segura



Trempe (grade) em ferro fundido.

Legenda Super Fogo



VOLTAGEM: Indica a voltagem para acionamento.



TEMPERATURA: Atinge até 315°C



Sem fumaça, e sem labaredas



ACENDIMENTO: Automático, pois não necessita de acendedores (esqueiros, fósforos, produtos químicos, etc...).



AGILIDADE: Rápido acendimento do carvão



INDICAÇÃO DE USQ para lareiras e churrasqueiras



SEGURANÇA: praticidade e segurança

Legenda Fornos



ACABAMENTO: Indica o principal material do acabamento do produto



TEMPERATURA: O forno mantém a temperatura programada



GRILL / DOURADOR: Indica que possui opção para Dourar



EMBUTIR: Indica a forma de instalação e uso



LUZ INTERNA / LUZ PILOTO: Indica as opções de iluminação que o produto possui.



RESISTÊNCIA INFERIOR: Informa a potência individual das resistências do forno.



FÁCIL LIMPEZA / AUTOLIMPANTE: Informa se o forno possui interior esmaltado de fácil limpeza ou se é autolimpante



TIMER: Indica o tempo limite de programação de preparo disponível.



RESISTÊNCIAS SUPERIOR: Informa a potência individual da resistências do forno.



ISOLAMENTO TÉRMICO: Não deixa o calor sair



AQUECIMENTO: Indica a temperatura máxima atingida pelo forno



POTÊNCIA TOTAL: Indica a potência total que o produto alcança



MEDIDA DE FORMAS: Indica o tamanho máximo de forma que cabe no forno



BOTÕES RETRÁTEIS: Indica que são aplicados botões modernos e práticos ao produto.



PÉS ANTIDERRAPANTES: Informa que o produto traz mais segurança.



ACOMPANHA GRELHA E BANDEJA: Acessórios que acompanham o forno

NARDELLI

A arte de fazer seu dia melhor

Rua Virgílio Franzoi, 30 - Galpão 01 - Bairro Gabiroba - Rio do Oeste-SC | www.nardelli.com.br